

ACTIVE NOISE CONTROL IN HEADSETS: A NEW APPROACH FOR BROADBAND FEEDBACK ANC

Thomas Schumacher, Hauke Krüger,
Marco Jeub, Peter Vary

Institute of Communication Systems and Data
Processing, RWTH Aachen University, Germany
[krueger, schumacher, jeub, vary]@ind.rwth-aachen.de

Christophe Beaugeant

Intel Mobile Communications,
Sophia-Antipolis, France
christophe.beaugeant@intel.com

ABSTRACT

In this paper a novel approach for broadband feedback active noise control (ANC) is presented which is based on the combination of classical non-adaptive feedback and adaptive feedback ANC techniques. The non-adaptive part is suitable to attenuate low frequency ambient noise whereas the adaptive part attenuates periodic components of the ambient noise. The proposed technique yields a higher overall noise attenuation performance compared to a purely classical non-adaptive feedback or purely adaptive feedback ANC system. In addition to that, the combination of both techniques is also beneficial for practical realizations since the adaptive feedback ANC stabilizes the overall system.

With regard to low cost headset devices, the impact of practical hardware constraints such as low-cost analog-to-digital and digital-to-analog converters (ADC, DAC) is discussed. As a conclusion, a mixed analog-digital realization of the new approach is proposed.

Index Terms— Active Noise Control, feedback ANC, mixed analog-digital

1. INTRODUCTION

The overall goal of active noise control (ANC) is to attenuate or cancel undesired ambient noise by emitting a compensation signal or *anti-noise* signal such that at a specific point, the undesired ambient noise and the anti-noise superpose in a destructive way. In the literature, the zone around the specific point where the signals cancel out is called the *quiet zone*. In case of ANC headsets, the anti-noise is emitted by the loudspeaker of the headset and the quiet zone is supposed to be located around the ear drum.

In [1], we have shown that **broadband feedforward ANC** approaches are strongly influenced by practical constraints. In particular, the lack of causality caused by analog-to-digital and digital-to-analog converters (ADC, DAC) with non-zero delay is a problem in digital realizations: The anti-noise arrives with a certain delay compared to the arrival of the ambient noise at the ear drum which severely limits the performance of the ANC system.

For this reason, a novel concept for broadband feedback ANC is proposed in this paper. It is based on the combination of non-adaptive feedback ANC (often denoted as classical feedback ANC) and adaptive feedback ANC techniques and enables to attenuate noise at low frequencies as well as periodic noise components at all frequencies. In addition to that, the new approach has the advantage that the adaptive part stabilizes the non-adaptive part. Compared to other approaches involving hybrid feedback ANC techniques, e.g., [2, 3], the two feedback ANC parts are decoupled which allows for independent design and optimization of both parts. The overall concept leads to a more comfortable perception of the residual ambient noise

compared to currently available ANC headsets. Aspects related to a realization of the new approach in low-cost ANC headsets are discussed, and a mixed analog-digital circuitry is proposed.

2. BROADBAND FEEDBACK ANC HEADSETS

A typical hardware setup for a broadband feedback ANC headset is shown in Figure 1. For the sake of simplicity, all signals are assumed

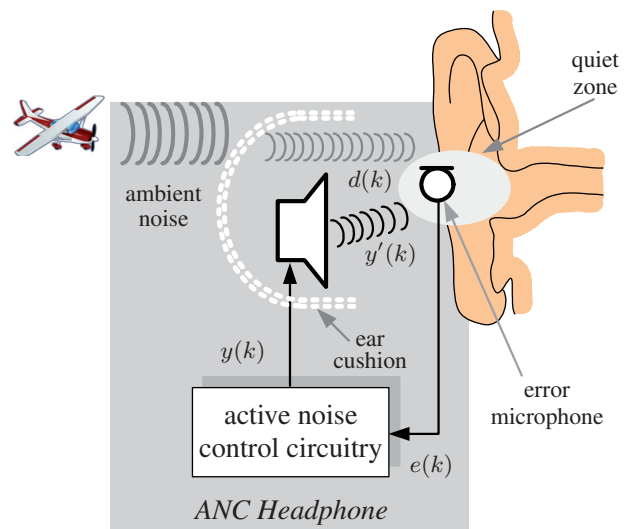

Fig. 1. Hardware setup of a broadband feedback ANC headset.

to be available in a time discrete representation with time index k . Note that only the problem to create a zone of quiet shall be addressed in this paper. In practical applications, often the playback of music or speech signals is also desired. The proposed concept can be easily extended towards the playback of audio signals which, however, shall not be considered in the following.

The ambient noise is attenuated to a certain extent due to a passive shielding of the headset or headphone. The remaining ambient noise $d(k)$ reaches the entrance of the ear canal and - with some delay - the ear drum. In order to combat the ambient noise perceived despite the passive shielding, signal $y(k)$ is produced by the *active noise control circuitry* and afterwards emitted by the loudspeaker to finally reach the position of the *error microphone* as signal $y'(k)$. At the error microphone, the *anti-noise* signal $y'(k)$ and the residual ambient noise $d(k)$ superpose to the error signal

$$e(k) = d(k) + y'(k). \quad (1)$$

In order to create the *quiet zone* around the error microphone, the signal $y(k)$ is computed such that the superposition of $y'(k)$ and $d(k)$ is destructive so that both signals cancel out as much as possible. If realized by digital technology, the analog-to-digital and digital-to-analog converters (ADC, DAC) introduce certain signal delays. It can be shown that feedback ANC approaches in general do not act as a noise canceler but, nevertheless, reduce ambient noise due to decorrelation (e.g. in [2]). As a conclusion, the attenuation of noise in one frequency region always comes to the price of a specific noise amplification in other frequency regions.

2.1. Non-adaptive (Classical) Feedback ANC

Approaches for feedback ANC in commercial headsets are nowadays mostly based on analog realizations of the ANC circuitry, e.g., [4, 5]. A model for a typical non-adaptive classical feedback ANC system is shown in Figure 2. The electrical and acoustical path between the output and the input of the ANC circuitry is described by the *secondary path* $S(z)$. $S(z)$ contributes for the properties of the power amplifier, the loudspeaker, the acoustic path and - in a digital ANC realization - also the digital-to-analog and the analog-to-digital converter (DAC, ADC). The *control filter* $W_c(z)$ transforms the error signal $e(k)$ into the anti-noise signal $y(k)$. In order to allow for a destructive superposition, the computed anti-noise is inverted before being emitted by the loudspeaker which is indicated by the minus sign in the figure. Assuming that the z-transforms of the signal $d(k)$

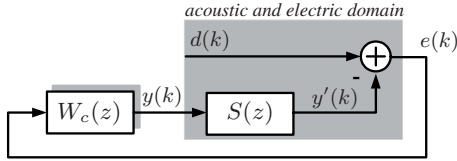

Fig. 2. Model for a classical feedback ANC system.

and $e(k)$ exist, the classical closed-loop ANC transfer function is given by

$$H_{cl}(z) = \frac{E(z)}{D(z)} = \frac{1}{1 + S(z) \cdot W_c(z)}. \quad (2)$$

A high attenuation of the ambient noise can be achieved by a high amplification caused by the control filter $W_c(z)$. However, a phase modification is introduced by the secondary path $S(z)$ which causes the system to become unstable if the amplification is too high. As a conclusion, the design of a control filter to guarantee stability based on Bode plots [6] and the consideration of stability criteria as given, e.g., in [7], both well-known in the context of control theory, is required. Based on this method, an attenuation of the ambient noise of up to 20 dB for frequencies below $f_{0dB} \approx 700$ Hz can be achieved in state-of-the-art ANC headphones.

Non-adaptive classical feedback ANC is very sensitive against delays caused by the ADC and DAC of the ANC circuitry. Simulations of different ADC converter delays showed that already a delay of $T_{delay} \hat{=} 15$ samples given a sampling rate of $f_s = 48$ kHz (which is often observed for Sigma-delta ADCs [8]) has the impact to cut the noise attenuation frequency bandwidth in half ($f'_{0dB} \approx 300$ Hz). For this reason most commercial ANC headphone devices are based on analog technology. Non-adaptive classical feedback ANC systems work particularly well in combination with closed headphones: While these devices have a passive attenuation against surrounding ambient noise in the order of magnitude of 20 dB for frequencies above 500 Hz, the additional noise attenuation due to the ANC circuitry covers the frequencies below 500 Hz.

2.2. Adaptive Feedback ANC

Adaptive feedback ANC is more similar to feedforward ANC than to the non-adaptive classical feedback ANC system described in the previous section. The basic principle of an adaptive feedback ANC system is illustrated by the model depicted in Figure 3. The key

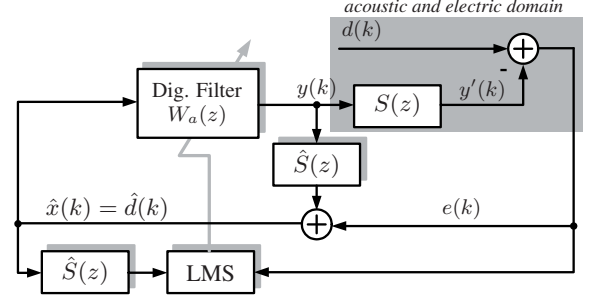

Fig. 3. Model for an adaptive feedback ANC system involving the FxLMS approach.

element of this approach is to compute an estimate $\hat{x}(k) = \hat{d}(k)$ of the ambient noise signal $d(k)$, derived from the error signal $e(k)$. In principle, $\hat{x}(k)$ plays the same role as the reference signal $x(k)$ in feedforward ANC [9] where it is sensed by an additional reference microphone. In the case of feedback ANC, however, the reference signal is *regenerated* based on an estimate $\hat{S}(z)$ of the secondary path (which is modeled by $S(z)$ in the figure) as

$$\hat{X}(z) = \hat{D}(z) = E(z) + Y(z) \cdot \hat{S}(z). \quad (3)$$

The anti-noise signal $y(k)$ is computed by means of filtering the estimate of the reference signal $\hat{x}(k)$ in the digital filter $W_a(z)$ which is continuously adapted to the given signals $x(k)$ and $e(k)$ following the *Filtered-X LMS* approach which is in detail described in, e.g., [9]. In analogy to (2), the corresponding closed-loop ANC transfer function is

$$H_{ad} = \frac{E(z)}{D(z)} = \frac{1 - \hat{S}(z) \cdot W_a(z)}{1 + [S(z) - \hat{S}(z)] \cdot W_a(z)}. \quad (4)$$

For the assumption $\hat{S}(z) = S(z)$, (4) simplifies to

$$H_{ad} = 1 - S(z) \cdot W_a(z) \quad (5)$$

3. THE NOVEL HYBRID FEEDBACK ANC

In order to exploit the benefit of both - the non-adaptive classical feedback and the adaptive feedback ANC approaches - in a hybrid concept, both concepts need to be concatenated so that the transfer functions (2) and (5) multiply. In practice, this kind of concatenation is not possible since only one error microphone and one loudspeaker are available. Therefore, the novel hybrid approach for feedback ANC as depicted in Figure 4 shall be considered. In that figure, the two ANC circuitry system functions from Sections 2.1 and 2.2 are denoted by $W_c(z)$ and $W_a(z)$, respectively. The resulting partial anti-noise signals are summed at position A to form the overall anti-noise signal $y(k) = y_c(k) + y_a(k)$ which is emitted by the loudspeaker and enters the secondary path $S(z)$ in the model¹.

¹Note that, again, the signal $y(k)$ is inverted prior to the acoustic emission which is shown as the minus sign in the figure.

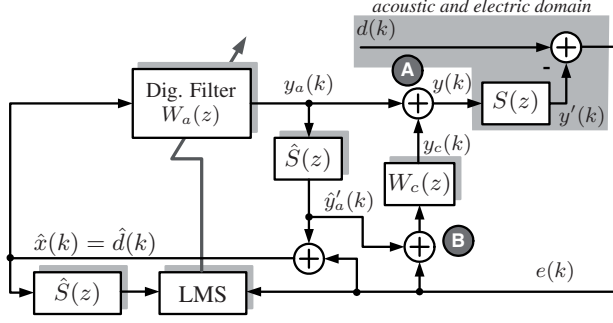

Fig. 4. The novel hybrid feedback ANC system based on the FxLMS approach.

The signal $\hat{y}'_a(k)$ is an estimate of the anti-noise signal resulting from the adaptive feedback part when reaching the error microphone. This signal is added at position B. As a consequence, the non-adaptive classical feedback ANC part does not have a direct impact on the adaptive feedback ANC part since the loop composed of $W_c(z)$ and $S(z)$ is disconnected for the anti-noise signal from the adaptive feedback part (signal $y_a(k)$). In fact, this is the most significant difference compared to the approach(es) proposed in [2, 3]. As a consequence, the non-adaptive classical and the adaptive part are decoupled, and the transfer function $\hat{S}(z)$ in the figure is the estimate of the secondary path according to the definition from Section 2.1. In contrast to this, an estimate of the system function related to the **combination of the secondary path and the non-adaptive control filter in the closed-loop structure from Figure 2** is required in the structure proposed in [2, 3]. This coupling of the classical and the adaptive feedback part causes that both parts must be designed and optimized jointly whereas in the solution proposed here, both parts can be designed and optimized independently. Also, the estimate of the secondary path in [2, 3] may lead to a slower convergence of the FxLMS filter adaptation due to a high signal attenuation in the lower frequencies and hence frequency areas which are almost unobservable for the adaptive feedback ANC part.

The overall closed-loop transfer function of the proposed approach is given as

$$H_{\text{novel}}(z) = \frac{E(z)}{D(z)} = \frac{1 - W_a(z) \cdot \hat{S}(z)}{1 + S(z) \cdot W_c(z) + W_a(z) \cdot (S(z) - \hat{S}(z))}. \quad (6)$$

Given that the secondary path is perfectly known, $\hat{S}(z) = S(z)$, the transfer function simplifies to

$$H_{\text{novel}}(z) = \frac{1 - S(z) \cdot W_a(z)}{1 + S(z) \cdot W_c(z)}. \quad (7)$$

From (7), it is obvious that both parts of the hybrid feedback ANC approach contribute to the overall attenuation of the ambient noise if the secondary path is perfectly known. As a conclusion, the block diagram from Figure 4 is equivalent to the concatenation of both, the classical and the adaptive feedback ANC part.

3.1. Mixed analog-digital realization

Low-cost digital audio hardware - in particular Sigma-delta analog-to-digital converters (ADCs) - nowadays used for audio applications

almost everywhere cause a certain system delay. As mentioned earlier, the classical feedback ANC part is very sensitive against signal delays. Also, the control filter $W_c(z)$ is in general fixed and not very complex. Therefore, it is more beneficial to realize this part in analog technology (analog control filter $W_c(s)$). The adaptive feedback ANC part, however, is based on the adaptation of a digital filter $W_a(z)$. This part targets the attenuation of periodic noise components and hence is not very sensitive against moderate shifts of $\hat{x}(k)$. Therefore, the adaptive feedback ANC part is robust against moderate signal delays caused by ADCs and DACs. As a conclusion, a variant of the proposed hybrid system is given in Figure 5 in which an analog non-adaptive classical feedback ANC system is extended by means of a digital adaptive ANC realization. Compared

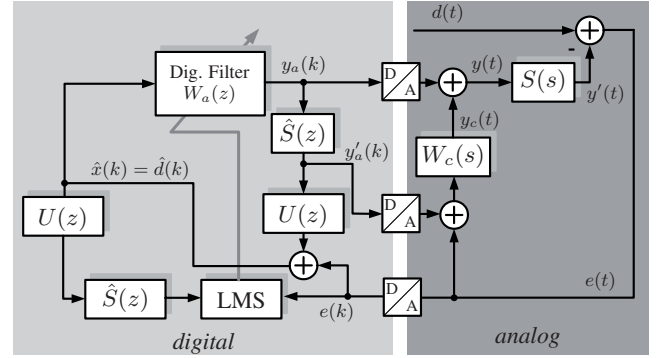

Fig. 5. Mixed analog-digital realization of proposed hybrid feedback ANC approach.

to Figure 4, the ADC and DAC were added together with the transfer function $U(z)$ to approximate the "real" transfer function of the concatenation of ADC and DAC in the adaptive part, respectively. Also, the secondary path $S(s)$ (according to the definition from Section 2.1) and the analog controller $W_c(s)$ as well as the signals $y(t)$, $e(t)$, $d(t)$ and $y_c(t)$ are given in the analog (Laplace) domain.

4. SIMULATION RESULTS

In order to test the proposed hybrid feedback ANC concept, simulations were carried out in Matlab. Basis for all simulations were measurements of the secondary path $S(z)/S(s)$ involving an in-ear headset and an error microphone located in close proximity to the loudspeaker of the headset. In order to contribute for the impact of the ear, the in-ear headset and the error microphone were placed inside an artificial ear canal for the measurements. All measurements and simulations were done for a samplerate of $f_s = 48$ kHz.

In the first step, the secondary path according to the definition from Section 2.1 was approximated by a 512-tap finite impulse response (FIR) filter to represent the in-ear headset loudspeaker, the acoustic path from within the ear canal, the error microphone and the microphone pre-amplifier from the in-ear headset loudspeaker. In the next step, given the approximation of the secondary path, a digital controller was designed to realize the classical feedback ANC part in the Matlab *Control System Toolbox* (SISO Design tool, [10]). For simulations of the proposed hybrid feedback ANC approach, an artificial signal $d(k)$ was produced based on a mixture of white Gaussian noise and sinusoids at frequencies of $f_0 = 103$, $f_1 = 401$, and $f_2 = 2005$ Hz. For the adaptive feedback ANC part, a conventional FxLMS approach involving an adaptive step size controller was developed which, however, shall not be described in detail here due to

the lack of space.

The noise attenuation curves produced for the assumption that the secondary path can be perfectly approximated by $\hat{S}(z)$ are illustrated by Figure 6. In that figure, estimates of the power spectra related to the signals $d(k)$ and $e(k)$ are plotted as $\hat{\phi}_{d,d}(f)$ and $\hat{\phi}_{e,e}(f)$, respectively, over the frequency f . In that context, $d(k)$ represents the residual ambient noise without ANC whereas signal $e(k)$ represents the ambient noise which remains despite ANC (refer to Figure 1). In the figure, $\hat{\phi}_{d,d}(f)$ is plotted in black color in the background whereas $\hat{\phi}_{e,e}(f)$ is plotted on top of $\hat{\phi}_{d,d}(f)$ in light gray color. In

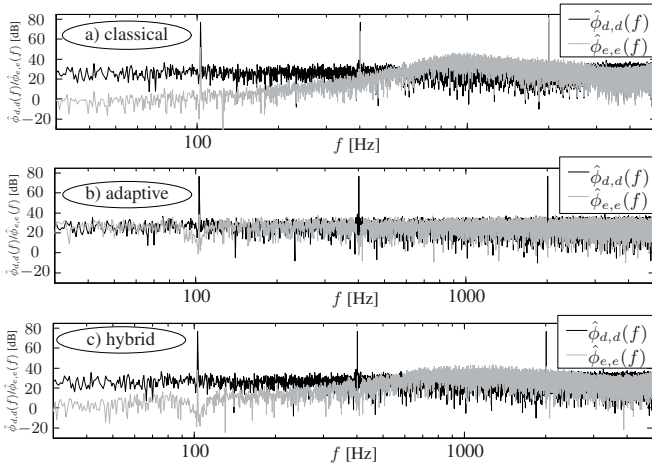

Fig. 6. Noise attenuation curves for a) the non-adaptive (classical), b) the adaptive and c) the novel hybrid feedback ANC approaches. The ambient noise signal is Gaussian white noise mixed with three sinusoidal signals at $f_0 = 103$, $f_1 = 401$ and $f_2 = 2005$ Hz.

the first part of the figure, the impact of the non-adaptive classical feedback ANC system (Section 2.1) is illustrated. Given that the ADCs and DACs cause no signal delay (the analog realization), this approach allows for a noise attenuation of up to 20 dB for low frequencies. The noise attenuation capability decreases towards higher frequencies, finally reaching 0 dB for $f_{0dB} \approx 700$ Hz. Above that frequency, the ambient noise is slightly amplified with a maximum ratio of ≈ 5 dB.

In the second part of the Figure, the approach solely based on the conventional adaptive feedback ANC (Section 2.2) is evaluated. A noise attenuation can be observed only in the area of the three periodic signal components which are visible as the three peaks in the power spectra. These components are almost completely removed from the ambient noise signal.

In the third part of the figure, the results achieved by the novel hybrid approach (Section 3) are shown. Obviously, ambient noise is attenuated in the lower frequencies due to the classical feedback ANC part. In addition, the periodic signal components are attenuated in a way very similar to the case of the ANC solely based on the adaptive approach. The hybrid scheme hence acts as the concatenation of both ANC parts.

Compared to the purely classical feedback ANC approach the attenuation of the ambient noise in the lower frequencies and the amplification of the ambient noise in frequency areas above 700 Hz are reduced and the noise amplification for frequencies higher than 700 Hz is reduced. This is a symptom of the stabilization property of the proposed approach: If frequency peaks occur in the spectrum of the residual noise, e.g., howling caused by the non-adaptive clas-

sical feedback ANC part, the adaptive feedback ANC part detects and attenuates these frequency components by adaptation. Therefore, the proposed concept is more stable and the remaining ambient noise appears to be perceptually more pleasant than in case of a purely classical feedback ANC headset. Also, the negative impact of suboptimally designed control filters $W_c(z)/W_c(s)$ can be partly compensated by the hybrid approach yielding a simplified design methodology for the non-adaptive part of feedback ANC headsets.

5. CONCLUSIONS

In this paper, a novel hybrid feedback ANC scheme was proposed which is based on the combination of classical and adaptive feedback ANC techniques. The proposed approach has the benefit to allow for the attenuation of noise in lower frequency areas as well as periodic noise components in all frequency areas. In addition, the adaptive part aids to stabilize the classical ANC part due to the adaptation of the involved adaptive filter to combat peaks in the spectrum of the residual ambient noise.

With respect to practical constraints, a mixed analog-digital realization is proposed to retain a very low system delay in the classical part and to enable the adaptation of the adaptive ANC part in the digital domain. The overall concept is suitable for low-cost ANC headsets yielding a higher quality noise attenuation performance than state-of-the-art ANC headsets currently available.

6. REFERENCES

- [1] Hauke Krüger, Marco Jeub, Thomas Schumacher, Peter Vary, and Christophe Beaugeant, “Investigation and development of digital active noise control headsets,” in *Proc. of Intl. Workshop on Acoustic Echo and Noise Control (IWAENC)*, Tel Aviv, Israel, Aug. 2010, IWAENC.
- [2] Marek Pawelczyk, “A hybrid active noise control system,” *Archives of Control Science*, vol. 13, no. 2, pp. 191–213, 2003.
- [3] Sen M. Kuo Ying Song, Yu Gong, “A robust hybrid feedback active noise cancellation headset,” *IEEE Trans. on Speech and Audio Processing*, vol. 13, no. 4, pp. 607–617, 2005.
- [4] A.G. Bose and J. Carter, “Headphoning - US Patent 4,455,675,” June 1984.
- [5] Harry F. Olson and Everett G. May, “Electronic sound absorber,” *Acoustical Society of America Journal*, vol. 25, no. 6, pp. 1130–1136, 1953.
- [6] H. Bode, *Network analysis and feedback amplifier design*, Verlag Van Nostrand, New York, USA, 1945.
- [7] H. Unbehauen, *Klassische Verfahren zur Analyse und Synthese kontinuierlicher Regelsysteme, Fuzzy-Regelsysteme*, Verlag Vieweg + Teubner, New York, USA, april 2008.
- [8] P.M. Aziz, H.V. Sorensen, and J. van der Spiegel, “An Overview of Sigma-delta Converters,” *IEEE Signal Proc. Mag.*, vol. 13, pp. 61–84, Jan. 1996.
- [9] Sen M. Kuo and Dennis R. Morgan, *Active Noise Control Systems: Algorithms and DSP Implementations*, John Wiley & Sons, Inc., New York, USA, Feb 1996.
- [10] The Mathworks, “SISO Design Tool,” <http://www.mathworks.com/access/helpdesk/help/toolbox/control/getstart/f2-1037701.html>, 2010.